

CT660



CT660

EXTERIOR

- Configurable as Truck or Day-Cab Tractor
- Aluminum Alloy Cab Construction, riveted and bonded for ease of repair
- Cat® exclusive stylized lightweight composite hood design with Open-Assist strut system
- Eye-catching robust all-metal grille and grille-surround providing years of service
- Modular Components for superior serviceability and repair cost management
- Excellent over-hood visibility

INTERIOR

- Cat exclusive design features
- Premium sound insulation kit
- Optimized Day-Cab suspension design for enhanced driver comfort and reduced driver fatigue
- Highly effective ergonomic cab for improved driver safety and productivity
- Mirrors designed for excellent secondary visibility and overall safety
- Interior materials selected and designed for exceptional noise reduction in cab
- Maximized Storage Capacity and Locations
- Superior Gauge and Rocker Switch layout leveraged from Cat Equipment design expertise
- Interior surfaces designed for optimum cleanability

CHASSIS

- Heat-treated alloy steel
- 12.0-inch rail size: 110,000 and 120,000 psi yield strength
- Length variable in 2.0-inch increments
- Designed to handle rugged applications with maximum durability
- Superior Turning Radius
- Available with inner rail reinforcements: one or two frame liners available
- SBA, 116-inch and 122-inch Bumper to Back of Cab (BBC) available

ENGINES

- Cat CT11 ratings from 330 bhp to 390 bhp and 1,450 Lb/Ft Peak Torque
- Cat CT13 ratings from 410 bhp to 475 bhp and 1,700 Lb/Ft Peak Torque
- Cat CT15 ratings from 435 bhp to 550 bhp and 1,850 Lb/Ft Peak Torque (Available first quarter 2012)
- EPA 2010 On-Highway Emissions Compliant Engines incorporating Advanced EGR system comprised of the latest advances in fuel injection technology, air management systems, combustion bowls and electronic controls
- Unique Engine ratings created specifically for Vocational applications, resulting in the ultimate horsepower/torque combinations

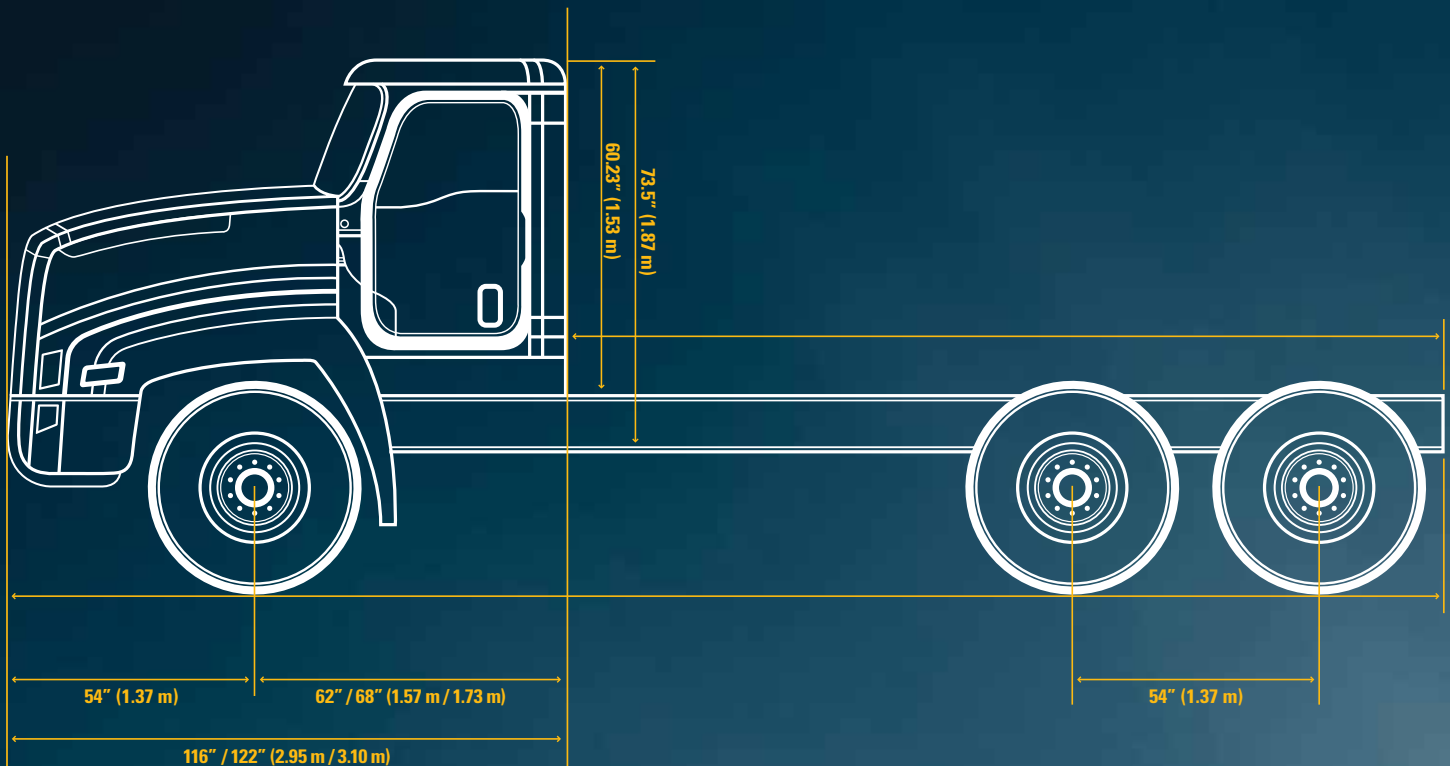

TRANSMISSION

- Power Take-Off (PTO) alternatives for the Cat CX31 Automatic Transmission include two side locations, and a Cat exclusive high output rear PTO. The optional rear PTO provides customers with improved packaging, performance and serviceability.
- Eaton Manual and Automated Manual Transmissions

SUSPENSION: FRONT

- Multileaf, shackle type, single or two-stage spring
- Multileaf, slipper type
- Compatible shock absorber selection

FUEL TANKS

- Fuel tanks available in 60, 80, 100 and 120 gallon capacities
- Single left, single right or dual options available
- Aluminum Alloy Construction

AXLES

- Meritor, Dana and Fabco options available
- 6X4, 8X6, 6X6, and 4X4 configurations available

SUSPENSION: REAR

- Hendrickson suspension offerings: HaulMaax, HN, RT/RTE, RS, R, PriMaax
- Chalmers high articulation

© 2010 Caterpillar Inc. | LEDT0028-02

All Rights Reserved CAT, CATERPILLAR, their respective logos, ACERT, "Caterpillar Yellow" and the "Power Edge" trade dress, as well as corporate and product identity used herein, are trademarks of Caterpillar and may not be used without permission.

